

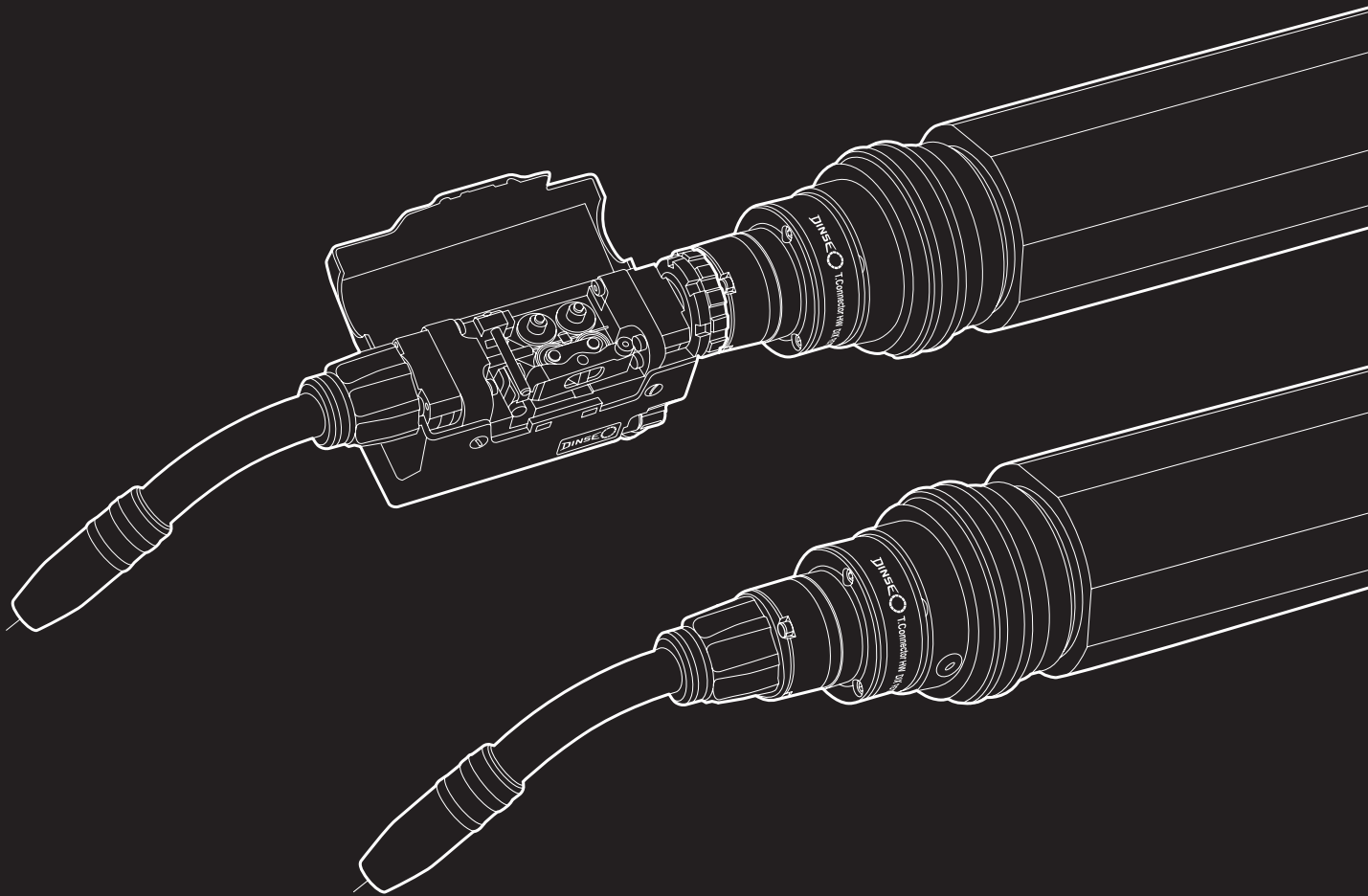

# HIGHEST PRECISION FOR HOLLOW-WRIST ROBOTS



## T.CONNECTOR HW & HWD

### Totally convincing:

- ▶ Perfect connection to the robot
- ▶ Easy installation
- ▶ Slim design and low weight
- ▶ Maximum flexibility through +/- 260° rotation
- ▶ Optional front drive: Single Feed, PUSH-PUSH and PUSH-PULL
- ▶ Optional wire brake available

**WITH SHOCK  
SENSOR**



# T.CONNECTOR HW

Constant stick-out, thanks to optional wire brake

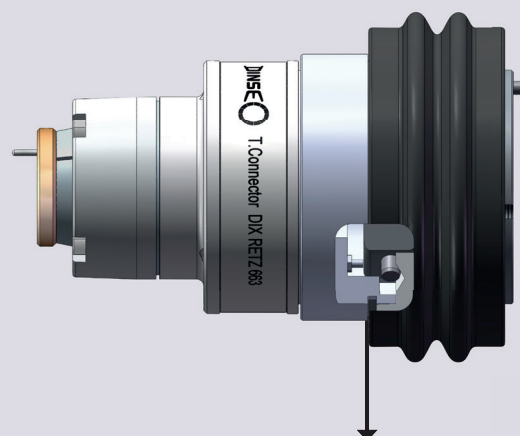

The proven system of the DIX SAS 100 shock sensor is integrated in the models T.Connector HW and T.Connector HWD

## EXTREMELY ROBUST

### Take advantage of first class quality:

With +/-260° of rotation, the T.Connector HW(D) allows maximum flexibility and optimal component accessibility. The high torsion-resistant hose package is characterized by its extremely low wear, long service life and long maintenance intervals.

According to the requirements the T.Connector HW(D) is available as gas- or liquid-cooled version.

## MODULAR DESIGN

### A fitting solution for each application:

The T.Connector HW(D) is available with or without wire brake. Touch sensing can be carried out by the end of the wire or the gas nozzle.

The wire brake ensures a constant stick-out during the measurement process. Even when parts have deviations or tolerances, a perfect welding result is ensured.

# T.CONNECTOR HWD

Holder for wire feed unit DIX FD 200 M / ME:  
Powerful drive for reliable wire feeding

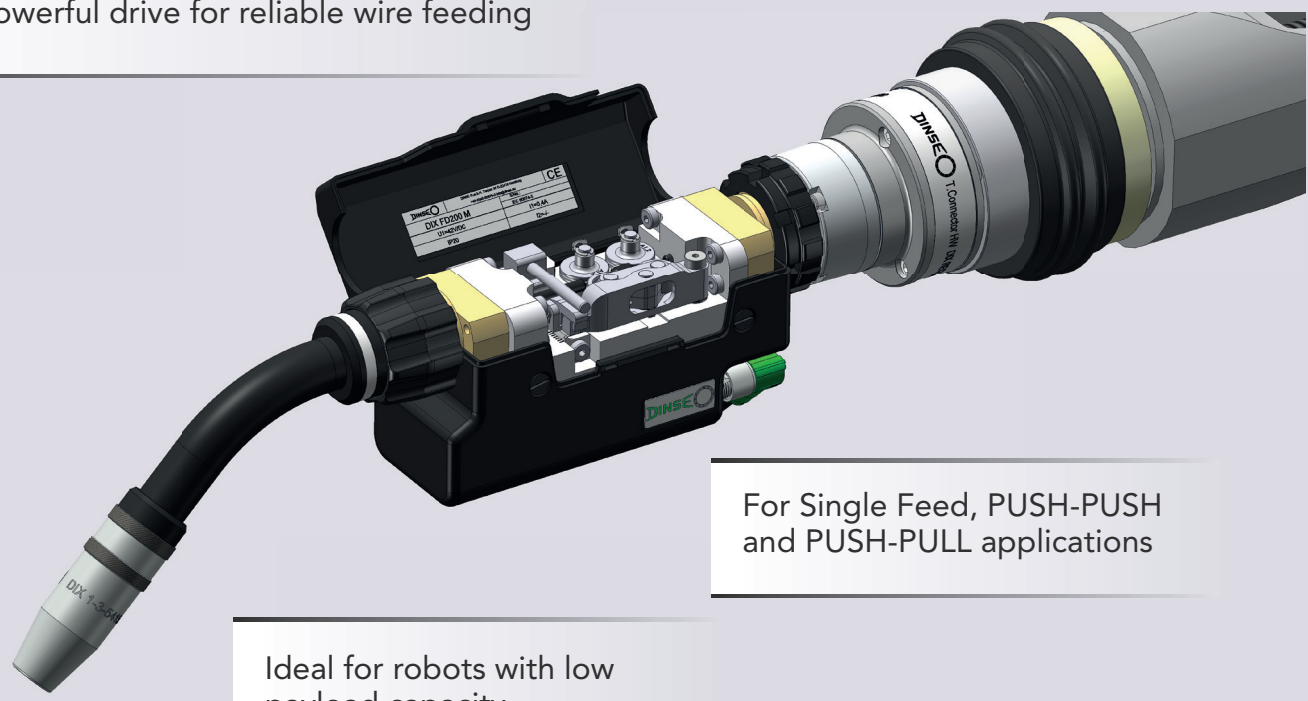

For Single Feed, PUSH-PUSH  
and PUSH-PULL applications

Ideal for robots with low  
payload capacity

## LIGHT AND RELIABLE

### Reliably better welding:

The integrated shock sensor with a deflection of 7° reset accuracy provides reliable protection during collision in the setup and automatic operation. The shutdown signal is carried out electronically.

Manufactured mostly out of aluminium, the T.Connector HW(D) has a very light weight. Therefore it is ideal for robots with a low payload capacity.

## EXCELLENT FEEDING

### Wire feeding is our specialty:

The model T.Connector HWD is additionally equipped with the powerful 4 roller drive DIX FD 200 M / ME. With its high tensile force it guarantees an extremely reliable conveying of the wire.

The DIX FD 200 M / ME is also suitable for the use of soft, buckling sensitive materials such as aluminium or copper alloys and for small wire diameters. A precise and accurate feeding over long distances and a stable arc are guaranteed. This eliminates time-consuming rework on the welding seam.

# TECHNICAL DATA

Technical data – Rotary interface T.Connector		HW (HWD)
Welding processes	MIG/MAG-welding and MIG brazing	
Protection class	IP 23	
Torsional moment	ca. 20.0 (43.0) Nm	
Cut-out torque	ca. 11.5 (26.0) Nm	
Rotation	+/- 260°	
Dimensions (Ø x L)	108 mm x 146,5 mm (198,6 mm)	
Weight (without torch set)	approx. 1.3 kg	
Ambient temperature (during operation)	+ 5° C - + 55° C / 14° F - + 104° F	
Wire diameter	0.8 - 1.6 mm	
Technical data - DIX FD200 M / ME		
Wire feed speed	0,4 - 20 m/min	
Wire diameter	Ø 0,8 - 1,6 mm	
Dimensions (L/W/H)	181/70,5/94,5 mm	
Weight	1,65 kg	
Parameters for liquid-cooled robotic and automatic torch sets according to DIN EN 60974-7		
Minimum water flow rate	1.1 l/min (0.29 gal./min)	
Pump pressure (dynamic pressure)	max. 6 bar (87 Psi max.)	
Maximum water temperature	55° C (131° F)	
Coolant	de-mineralized (de-ionized) water	
T.Connector HW(D) & FD 200 M / ME		Cooling / Variant
RET 363 - x	gas-cooled / -	
RET 363 - x/WB	gas-cooled / wire brake	
RETZ 663 - x	liquid-cooled	
RETZ 663 - x/WB	liquid-cooled / wire brake	
RETZ 363D - x	gas-cooled / -	
RETZ 663D - x	liquid-cooled / -	
FD 200 M / ME	liquid-cooled	

Your dealer:



DINSE is your dependable partner for the entire welding process. Contact us and schedule an appointment for personal consultation today! Together with you we will find the best solution for your application.



+ 49 (0)40 / 658 75 – 255



T.ConnectorHWD@dinse.eu